

## RESEARCH REPORTS

# The design of a four-seat reverse delta WIG craft

---

**HASSAN HAMEED**, *The Maldives National University*

**ABSTRACT** *A 4-seat Wing in Ground effect craft was designed informed by an extensive literature review of past efforts in WIG craft engineering. Several designs were considered during concept evolution. The review identified a reverse delta configuration as best meeting the design requirements. A one-fifth scale of the craft was modelled using blue polystyrene foam and flown using an electric motor in pusher configuration. The flight test verified the design concept, and the effectiveness of the design. A key consideration for effective flight is undercambered airfoils to reduce take-off distance. The model was flyable in sea-state 1. It is estimated the full-size craft can get airborne in sea-state 2. A full-scale model is envisaged.*

**KEYWORDS** *Wing-in-ground effect craft, WIG, ekranoplan, aircraft design, rc models, airfish, Airfish, ground effect, stability, reverse delta, Lippisch. Bavar-2*

The International Maritime Organization (IMO) defines a Wing in Ground (WIG) craft as a multimodal craft which flies by using ground effect above the water or some other surface, without constant contact with such a surface and supported in the air, mainly, by the aerodynamic lift generated on a wing (wings), hull, or their parts, which are designed to utilize the ground effect action (IMO, 2002).

IMO recognizes three types of WIG craft: A, B and C. Type A craft certified for operation only in ground effect; Type B is certified to temporarily increase its altitude to 150 m above the ground or sea, whereas the Type C craft is certified for operation outside of ground effect and exceeding 150 m above the surface. Wing in Ground (WIG) craft is particularly suitable for countries with small islands and large bodies of water. This is because, unlike aircraft, WIG craft are considered ships although they do fly in the air. However, as they are not considered aircraft these craft have much less stringent safety requirements and are hence cheaper. Additionally, flying in ground effect requires much less energy. These two factors make WIG craft operations cheaper and attractive.

This paper describes the design of a four seat reverse delta WIG craft. The paper begins with an extensive review of WIG craft and discusses the design considerations in the light of operational designs informed by the systems engineering approach outlined by Sadraey (2012).

---

This study was supported by a Research Grant from the Maldives National University.

### **Aim**

The aim of the project was, first, to gather all the essential literature on the design of reverse-delta WIG craft of the Lippisch type, and design a full scale craft. Second, the project aims to build and test a one-sixth scale model of a 4-seat WIG craft. The WIG craft should be stable in flight and controllable using normal RC aircraft servos, controls and motors.

### **Scope**

The scope of the research was limited by the materials available and targeted at the design of the full-scale model. Thus, the emphasis was on establishing the stability parameters of the craft in flight and the efficiency of take-off. The model has to be powered by available electric rc model motors and thus cannot exceed one-fifth of the scale. While carbon fibre cloth was available in the local market, the time available and experience of the fabricators dictated against its adoption.

### **Significance**

WIG craft hold extraordinary technological advantages for transforming the development of the country. The territory of the Maldives is 99% sea, and the land area is only 298 square kilometres. This land is, however, distributed over 1192 islands most of which are quite small. In fact, of all the inhabited islands, 80% of them have an area less than a square kilometre (National Bureau of Statistics, 2016). The sparse population and its distribution over a wide expanse of sea constrain development in all spheres of human activity owing to transport costs.

WIG craft is particularly suitable for the Maldives because of its costs, safety and speed than the current modes of transport. The common 13-seat high speed boats travel about 20 knots, usually powered by  $2 \times 250$  hp gasoline engines. Air transport serves only few islands and is costly. By comparison, a 4-seat WIG craft may be powered by 100 hp engine and the speed would be about 100 knots. The skills of fibreglass boat-building can be easily adapted to WIG craft manufacture. Thus, WIG craft transport may dramatically change the economy and development of the country.

### **Literature Review**

Ground effect has been known, at least, for the past 80 years. Hollebone (2012) cited a National Advisory Committee for Aeronautics (NACA) memorandum (numbered 771) dated 1934, which contained a summary of known findings about ground effect. The summary was a translation from a French author, M. L. Sueur, who had suggested using ground effect (GE) for economic and rapid transport especially over water. Rozhdestvensky (2000) noted that T.J. Kaario of Finland had been the first engineers involved in the development of GE craft from 1935. These were sledges which utilize the GE. Photographs of the craft and a US patent

(3261491) filed on September 29, 1962 and granted four years later about a system for controlling altitude and pitch in a ground effect vehicle leave no doubt about the predominance of the Finnish engineer in GE experiments.

There are many types of WIG craft. Yun, Bliault, & Doo (2010) outline the types, and their performance and design characteristics. This book is possibly the most authoritative text on the subject at present. Other reviews include those of Rozhdestvensky (2000, 2006), Halloran & O'Meara (1999). This review focuses only on the reverse delta "Lippisch" WIG craft and begins with the early development of Lippisch WIG craft and concludes by summarizing its development till the end of 2014.

The credit for the first GE marine vehicle will probably go to the Russian fast ship designer, R.Y. Alexeyev, who had a GE craft built in 1960 (Yun et al, 2010). It first flew at speeds of 200 km/h on 22 July 1961. However, Russian WIG craft development was unknown in the West due to the secrecy surrounding the project and the Cold War. In the West, Alexander Lippisch, a German aeronautical engineer known for many aeronautical innovations, including delta-shaped ( $\Delta$ ) wings for supersonic aircraft is credited with the development of the WIG craft. After the Second World War, he migrated to the US and continued his work on delta wings

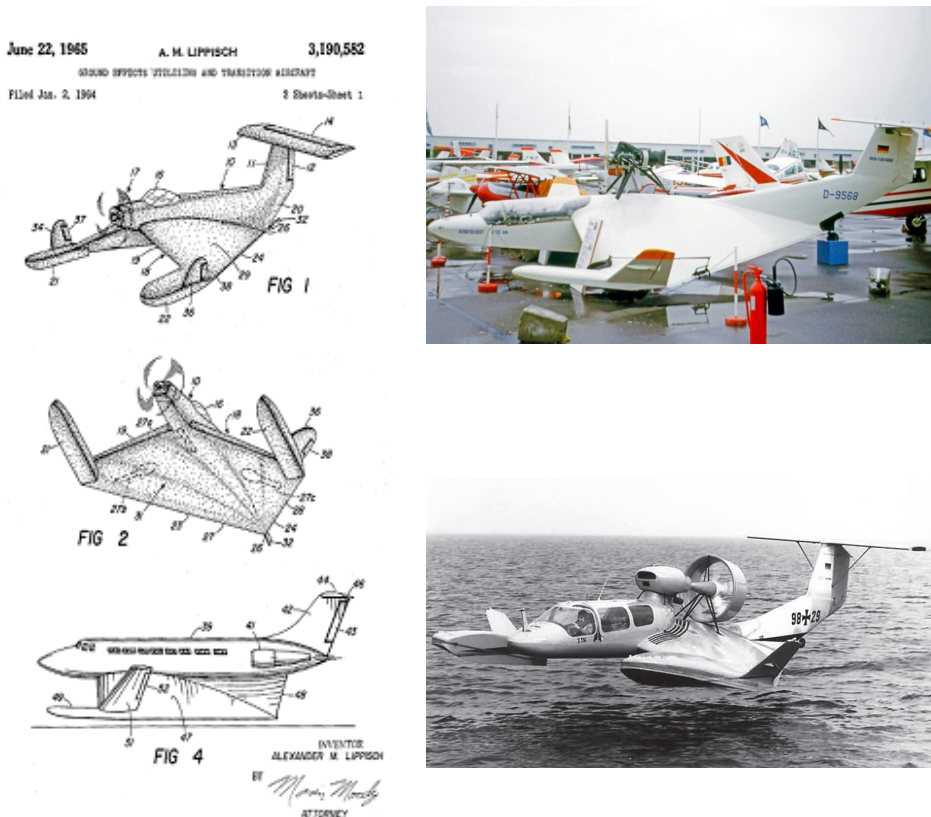

Figure 1. On the left is the original drawings of the Lippisch patent for the WIG craft. On the right at the top is X-113, and below it is X-114.

Source: Google patents

Table 1  
*Specifications of X-113 and X-114 (after Yun et al (2010))*

|                              | X-113                            | X-114                                   |
|------------------------------|----------------------------------|---|
| Length (m)                   | 8.43                             | 12.83                                   |
| Wingspan (m)                 | 5.89                             | 8.77                                    |
| Height (m)                   | 2.0                              | 2.92                                    |
| <i>Weights</i>               |                                  |   |
| Empty (kg)                   | 250                              | 1,040                                   |
| Fuel (kg)                    | 11                               | 80                                      |
| Payload (kg)                 | 99                               | 380                                     |
| Maximum take-off weight (kg) | 360                              | 1,500                                   |
| Payload fraction             | 0.275                            | 0.253                                   |
| <i>Propulsion</i>            |                                  |   |
| Engine                       | Nelson H63-CP                    | Lycoming IO-360                         |
| Type                         | Air-cooled 2 cylinder            | Air-cooled 4 cylinder                   |
| Power (kW)                   | 36                               | 180                                     |
| (bhp)                        | 48                               | 240                                     |
| Propeller                    | Two-bladed wooden open propeller | Three-blade 1.2-m ducted variable pitch |
| <i>Performance</i>           |                                  |   |
| Take-off speed (kph)         | 40                               | 100                                     |
| Cruise speed (kph)           | 80                               | 150                                     |

for the US military. In 1964, he filed for a patent (patent number: 3,190,582) for a reverse (or inverse) delta aircraft, which was granted in 1965. The patent set out the details of the aircraft. The patent noted that a model of gross weight of 550 pounds (250 kg) and 14 feet (4.3 metres) in wingspan had been tested and found to be using 1/3 of the take-off horsepower while in GE flight. This model had been called X-112 and was tested in 1963. X-112 survives and is EAA Air Venture Museum in the US.

His next two models, X-113 and X-114 were developed by a German company, Rhein-Flugzeugbau (RFB) with support from the German military. X-113 was 19 feet 4 in in wing span (5.9 m), and was found to be able fly in GE up to 50% of the span of the craft. X-114 was larger, the wing span was 23 feet (7 metres) and the length of the aircraft was 42 feet (12.8 metres). Powered by a Lycoming 200 hp engine, it is capable of carrying 6 passengers (Yun, Bliault, & Doo, 2010). Unlike the later and previous craft, the passenger pod was above the water line in X-114. A pilot error damaged the craft while experimenting with hydrofoils (Yun et al. (2010)). It was capable of flying in significant rough water over the Baltic Sea (Cole, 1989). Table 1 shows the specifications of X-113 and X-114.

RFB's technical director, Hanno Fischer took the task of WIG development from RFB and created his own company, Fisher Flugmechanik, to further the

development of the craft (Cole, 1989). Based on the experiences of X-112, X-113 and X-114, Fischer built a newer version of the WIG craft. It was called Airfish-1. Cole (1989) noted that a model of Airfish-1 was tested by fixing it on the roof of a car and driving the car at speed on German autobahn. According the Fisher Flugmechanik website, the major design strategy for Airfish-1 was to develop a fast ship rather than a ship capable flying. Free flying ability was curtailed to ease registration as a ship. It flew at 100 kph on 13 hp. The follow-up model, Airfish-2, had the fuselage of Airfish, a new wing and modified tail surfaces. The purpose of the change to the design of the wing is to reduce wing span so that the craft can be easily maneuvered in marinas.

Airfish-2 is now displayed in a German museum (Merseburg Technik Museum). Results from Airfish-1 and Airfish-2 led to the development of Airfish-3 which was built by a glass fibre fabrication company in Holland called Radius. Flight videos of Airfis-3 are on Youtube and its specifications are widely available on Internet. Air Fish-3 was one of the more successful of the developments. Based on the design

Table 2  
*Specifications of Airfish-3 and Airfish-8*

|                              | Airfish-3A                      | Airfish-8                           |
|------------------------------|---------------------------------|-------------------------------------|
| Length (m)                   | 9.45                            | 17.45 (17.22*) [16.75]              |
| Wingspan (m)                 | 7.93                            | 15.55* [15.6]                       |
| Height (m)                   | 2.6                             | 2.98 (4.0*) [4.0]                   |
| <i>Weights</i>               |                                 |                                     |
| Empty (kg)                   | 540                             | -                                   |
| Fuel (kg)                    | 32                              | -                                   |
| Payload (kg)                 | 128                             | -                                   |
| Maximum take-off weight (kg) | 700                             | 4750                                |
| Payload fraction             | 0.182                           | -                                   |
| <i>Propulsion</i>            |                                 |                                     |
| Engine                       | BMW 1200                        | GM [LS7V8]                          |
| Type                         | Air-cooled 2 cylinder, 4 stroke | Car engine                          |
| Power (kW)                   | 67@7,500 rpm                    | 402                                 |
| (bhp)                        | 90                              | 335                                 |
| Propeller                    | Six-blade, 1.1-m ducted fan     | Two four-blade variable pitch 1.7 m |
| <i>Performance</i>           |                                 |                                     |
| Take-off speed (kph)         | 40                              | 102                                 |
| Cruise speed (kph)           | 120                             | 159                                 |

Data: \*Rozhdestvensky (2006), Data for Airfish-8 from Aviation International News, January 22, 2008. Data in [square brackets] from a provisional registration certificate available at widgetworks.com. The certificate states that the keel of Airfish-8 was laid in 2001.



*Figure 2.* On the top is Airfish-2 and on the bottom is Airfish-3. The Airfish-3 is one of the more successful models of WIG.

and at the request of an Asian company, Airfish-8 was developed which seated 8 persons. The craft was built by Radius as well. Photos of the fabrication process were on Radius website earlier and but they had been removed as of now. Some photos of the fabrication stages were published in an introductory article on WIG craft by Hameed (2016). The craft was made from GRP. The specifications of Airfish-3 and Airfish-8 are listed in Table 2 after Yun et al. (2010). Rozhdestvensky (2006) listed dimensions of Airfish-3 as follows quoting a conference paper by Fischer: length=9.45 m, wingspan=7.93 m. Other Airfish-3 data are from Yun et al (2010).

Fischer had attempted to commercialize the craft, at least, three times. The first time, it was with Flarecraft, a US company; the deal fell through when Flarecraft reneged on the license agreements and wanted to make its own copies of Airfish-3. The second time, it was with Flightship Ground Effects, Australia, based in Cairns at whose request Airfish-8 was made. The company went into liquidation as reported by FlightGlobal.com dated 3rd February 2003. Airfish-3 and Airfish-8 became the property of one of the investors of the Australian company, a Singaporean. Airfish-3 is on display at a Singapore university and Flightship-8 was to be commercialized by a Singaporean company called Widgetworks Pte. Ltd. Flightship-8, renamed as Airfish-8, was damaged while testing as reported by the Malaysian newspaper, *The New Strait Times*, on August 29, 2012. Airfish-3 and similar models had the disadvantage that the take-off power required is much more than the cruise power.



Figure 3. The Korean Aron-7 and WSF-50 (inset). South East Asia now leads in the development of WIG craft.

Table 3

*The specifications of Aron-7 and Hoverwing HW-20 (Data from company websites)*

|                              | Aron-7                                  | Hoverwing-20   |
|------------------------------|---|--|
| Length (m)                   | 10.8                                    | 23.5   |
| Wingspan (m)                 | 12 (cabin width 1.4)                    | 24.1   |
| Height (m)                   | 2.95                                    | 5.7  |
| <i>Weights</i>               |   |  |
| Empty (kg)                   | 1270                                    | 6504   |
| Fuel (kg)                    | (200 litres)                            | 2400   |
| Payload (kg)                 |   | 3496   |
| Maximum take-off weight (kg) | 1800                                    | 9500   |
| Payload fraction             | (5 persons, 530 kg)                     | 0.368  |
| <i>Propulsion</i>            |   |  |
| Engine                       | Lycoming 540                            | Walter M601D   |
| Type                         | Piston, horizontally opposed air-cooled | Turbine  |
| Power (kW)                   | 125                                     | 2 × 559  |
| (bhp)                        | 300                                     | 2 × 750  |
| Propeller                    | Controllable pitch                      | 2 Muhlbauer MTV-27-1-E-C-F-R(W) CFR230<br>5-blade 2.3m |
| <i>Performance</i>           |   |  |
| Take-off speed (kph)         | 100                                     | 110  |
| Cruise speed (kph)           | 180                                     | 140  |

One method to reduce take-off power is to blow air under the wings. This method is called power-augmented ram wing-in-ground effect (PARWIG). PARWIG reduces the take-off distance and landing performance (Yun et al., 2010). Fischer had tested PARWIG on Airfish-3 and later designed a craft what he called Hoverwing using a similar method. Hoverwing has two small hulls as in catamarans. Air from the slipstream of the propeller is channelled into the space between the hulls to create additional lift for take-off. A scale model (Hoverwing 2VT) of a larger craft was tested and found to meet the design parameters.

Fischer's third involvement with the commercialization of the technology was with a company in South Korea: Wing Ship Technology Corporation. A Hoverwing type WIG craft of 50 seats was successfully trialled in May 2013. The brochure available from the company website notes its length as 29m, width as 27 m, height as 7 m, cruising speed as 180 kph. The craft is equipped with turboprop engines driving two 6-blade propellers. A smaller version, Hoverwing HW-20 with 20 seats was under construction in Germany in 2013. Another South Korean company, C&S AMT which was established in 2008 and renamed Aron Flying Ship Company in 2012, had commercialized the production of another WIG craft. Their craft, Aron-7 looks more like a Russian ekranoplan than a Lippisch WIG craft. There have been overseas sales of Aron-7 as of 2013. Aron-7 and the Hoverwing craft Wing Ship Technology Corporation, WSF50, are shown in Figure 3. The specifications of Aron-7 and Hoverwing HW-20 are shown in Table 3.

There has been another German development with regard to WIG by the name of Seafalcon. Since 1997, Seafalcon had been working on commercialization of a WIG craft. The initial focus was on developing a two-seater with two engines. After successful trials, Seafalcon began work on a full-sized glass-fibre plastic craft in 2003. However, in 2007, the craft was damaged according to the company ([www.seafalcon.net](http://www.seafalcon.net)). After, reorganizing the company in 2014, work had started anew on redeveloping a commercial WIG craft. The details of the craft, an 8-seater, are given in Table 4 and the craft is shown in Figure 4.

Table 4  
*The Specifications of Seafalcon*

| Attribute                     | Size  | Attribute                                       | Size |
|-------------------------------|-------|---|------|
| Length (m)                    | 13.72 | Take-off speed (kph)                            | 90   |
| Wingspan (m)                  | 11.5  | Cruise speed (kph) (max 180)                    | 150  |
| Height (m) in flare mode      | 2.6   | Maximum Range (km) (8 hrs)                      | 1200 |
| Flotation depth (m)           | 0.32  | Engine Power (kW)                               | 250  |
| Seats                         | 8     | Max. wave height (for take-off and landing, m ) | 0.85 |
| Maximum take-off weight (kg)  | 2300  | Ground clearance capability (m)                 | 10   |
| Noise in cruise at 100 m (dB) | 75    | Maximum payload (kg)                            | 900  |

*Source: [www.seafalcon.net](http://www.seafalcon.net)*



Figure 4. Seafalcon is made of glass-reinforced polymer.

### Russian and Chinese Developments in WIG craft

By far, the greatest developments in WIG craft had taken place in Russia, followed by China. In Russia, WIG craft known by the Russian name, ekranoplan, had been routinely used since the 1970s. Some models are in series production and find commercial application in the Caribbean and Russia. Yun et al (2010) and Rozhdestvensky (2006) discuss the development of WIG craft in Russia and China (and in some few other countries) in great detail. For the sake of brevity these discussions are not outlined in this review. However, the Lippisch-type Russian designs find pertinence for a brief discussion here.

One of the earliest Lippisch WIG craft built and used for a long time was Eska-1 (Ekranolyetniy Spasatel'niy Kater-Amphibia or screen-effect amphibious

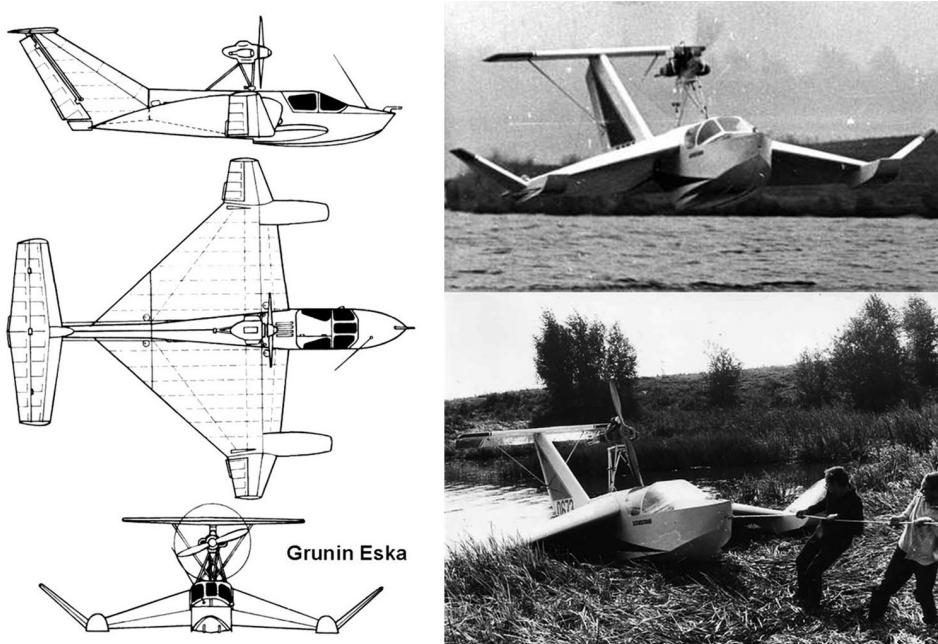

Figure 5. The Russian-made Eska was used for over five years.

lifeboat). It was designed by Eugene P. Grunina, a student at Moscow Institute of Civil Aviation Engineers (MIIGA) in 1973 and used as a rescue craft for nine years on Volga (Грунин ЭСКА-1, n.d.; Russian lifeboats can fly, 1974). The craft was based on Lippisch designs having seen photographs of X-113 and X-1145 and preceded Airfish development. This particular 2-seater craft was built from wood and cloth with a motorcycle engine. The specifications are in Table 5. A three-view drawing of Eska-1 and another Russian Lippisch is shown in Figure 5. Its construction details are widely available on Internet, for example in the webpage cited. Most of the Russian WIG craft (ekranoplans) are not of the Lippisch type; the designers preferring wing shapes more like conventional aircraft, possibly due to the cumbersome nature of reverse delta wings and the large take-off weights involved (for some craft such as “Lun”; it was 400 tonnes).

Table 5  
*Specifications of Eska 1*

| Attribute                        | Size   | Attribute               | Size   |
|----------------------------------|--|-------------------------|--|
| Length (m)                       | 7.8  | <i>Propulsion</i>       |  |
| Wingspan (m)                     | 6.9  | Engine                  | 1TD M-63   |
| Height (m)                       | 2.2  | Type                    | Piston,<br>horizontally<br>opposed<br>air-cooled |
| Wing area (m <sup>2</sup> )      | 13.85  | Power (kW)              | 24   |
| Airfoil                          | Wing Clark-Y, twisted<br>from 4.5 at root to<br>2.5 deg at tip. Stabila-<br>tor NACA 0009 at<br>5% to horizontal | (bhp)                   | 32   |
| <i>Weights</i>                   |  | Propeller               | 1.6 m<br>(wood fixed<br>pitch)                   |
| Empty (kg)                       | 234  | <i>Performance</i>      |  |
| Fuel (l)                         | 20   | Take-off speed<br>(kph) | —  |
| Payload (kg)                     | 2 persons  | Cruise speed (kph)      | 100  |
| Maximum take-<br>off weight (kg) | 450  | Maximum speed<br>(kph)  | 140  |
| Payload fraction                 | 0.33   | Range (km)              | 350  |
|                                  |  | Flying height (m)       | 0.3 – 1.5  |

Source: <http://airspot.ru/catalogue/item/grunin-eska-1>

China has been involved in the development of WIG craft since the 1960s ((Yun et al, 2010). Different types of WIG craft including Lippisch ones have been developed and are being marketed. Yun et al (2010) discuss the types and specifications of many craft of Chinese origin. Most craft are characterized by



Figure 6. The WIG craft above can carry up to 15 passengers. The one on the right is a trade fair display of a Chinese WIG craft in UAE. Though it is not of the Lippisch type, it is instructive to note the airfoil.

PAR styles and appear to have been greatly influenced by Russian designs. In fact, recently joint ventures between China and Russia regarding development of WIG craft have been announced (WIG aircraft, 2013). Figure 6 shows two WIG craft of Chinese origin.

### Iranian WIG craft

In 2010, Iran announced that Bavar 2, a “radar-evading” fixed-wing WIG craft are to be given the Iranian Navy. On the day of the announcement, 11 of these WIG crafts were delivered to the navy fleet. As Figure 7 shows, there is close resemblance between Bavar 2 and Eska-1 (Sammyanddaiana, 2012). The craft has a seating capacity of one to two. Videos of assembly process and the craft flying are widely available on Internet. These videos suggest that the craft is aerodynamically stable.



Figure 7. The Bavar 2 WIG craft of the Iranian navy.  
Source: Fars News Agency

Iran has also produced civil version of the craft. In 2015, a two-engine larger version was identified by satellite imagery but Iran has not announced it as yet. The larger one is approximately 18 metres long and 17 metres in wingspan (Chris B, 2015).

In summary, many experimental craft based on WIG have been designed since the 1930s. Lippisch reverse delta craft have been a popular focus for WIG development in Germany, Russia and China for the past 60 years. Several attempts at commercialization of WIG craft have been made in the past, notably in the US, South Korea, Australia and Singapore. WIG craft are now being used in the navy in, at least two countries, South Korea and Iran.

The conclusion that can be drawn from the development of Lippisch craft in the past is that they are aerodynamically stable in flight and hold much promise for cheaper transportation at aircraft speed. This is borne by the long trials of such craft as Eska-1 and Airfish-3. What is needed is a four-seat WIG because the demand for a four seat craft is likely to be higher. The four-seat Cessna Skyhawk is the best-selling, most-flown plane *ever built* according to the company website. Thus, it is likely that a four-seat reverse delta WIG craft can be the one that could drive WIG craft into mass market popularity.

### **Design of Experimental WIG Craft**

In this section, the design of the aircraft is discussed in relation to existing designs. According to Sadraey (2012), the systems engineering approach to aircraft design involves, first, the determination of the aircraft's maximum take-off weight (MTOW), second, the determination of wing area and engine thrust (simultaneously). One method of estimating MTOW suggested by Sadraey is by using the MTOW values of aircraft of a similar nature. The other method is to breakdown the aircraft weight into different components and then estimate or calculate each weight based on equations. The first method is outlined in the next section.

#### **Maximum Take-off Weight, Wing Loading and Thrust**

Table 6 shows the specifications of some four-seat aircraft, including seaplanes. The average weight of 4-seat land aeroplanes is 1148 kg. Seaplanes are heavier because the hull must provide buoyancy and withstand the hydrodynamic forces when landing and those due to wave action. In fact, the average gross weight of the four-seat seaplanes is 1418 kg. From summing the weights of individual components (horizontal and vertical stabilizers, engine and propeller system, hull, instruments, etc.) of the WIG, an MTOW value of 1200 kg was found to be adequate. The six-seater X-114 has an MTOW of 1500 kg, so this value seems right given the anticipated composite construction.

What sets WIG craft apart from land planes is the wing loading. From Table 6, the average wing loading in kilogrammes per square metres is 77.3. For the seaplanes, the average is 87.3. These values may be compared with WIG wing loading data. Wing loading for Eska-1 is 32.3 kg/m<sup>2</sup> and for the Lippisch X-112, the value is 32.2 kg/m<sup>2</sup> — the two values are very close. X-114 with a wing loading of 62.5 kg/m<sup>2</sup> has a take-off speed of 100 km/h whereas Seafalcon with a wing

Table 6  
Specifications of Some 4-seater Aircraft

| Aircraft               | Engine (typical)        | Power (hp) | Gross Wt (kg) | Useful Load (kg) | Stall Speed (kts) | Cruise Speed (kts) | Wing-span (m) | Length (m) | Wing Area (m <sup>2</sup> ) | Wing Loading (kg/m <sup>2</sup> ) |
|------------------------|-------------------------|------------|---------------|------------------|-------------------|--------------------|---------------|------------|-----------------------------|-----------------------------------|
| Robin DR400            | Lycoming O-235-F        | 120        | 900           | 350              | 44                | 116                | 8.72          | 6.96       | 14.2                        | 63.4                              |
| Piper Pacer            | Lycoming O-320-B        | 160        | 907           | 404              | 43                | 116                | 8.92          | 6.25       | 13.7                        | 66.2                              |
| Bede BD-4              | Lycoming O-320          | 150        | 910           | 458              | 45                | 172                | 7.8           | 6.53       | 9.51                        | 95.7                              |
| Piper PA-28-161        | Lycoming 320            | 160        | 975           | 430              | 47                | 108                | 9.2           | 7.16       | 15.14                       | 64.4                              |
| Zenith                 | Lycoming O-360          | 180        | 1000          | 478              | 34                | 91                 | 9.55          | 7.5        | 15.5                        | 64.5                              |
| Cirrus SR20            | Continental IO-360-ES   | 200        | 1025          | 624              | 60                | 183                | 11.68         | 7.92       | 13.5                        | 75.9                              |
| Maule M7-180           | Lycoming O-360-C1F      | 180        | 1136          | 483              | 35                | 120                | 10.03         | 7.21       | 15.39                       | 73.8                              |
| Tecnam p2010           | Lycoming IO 360-MIA     | 180        | 1160          | 450              | 55                | 133                | 10.5          | 7.54       | 14.6                        | 79.5                              |
| Diamond DA40           | Lycoming IO 360         | 180        | 1198          | 403              | 49                | 150                | 11.9          | 8.1        | 13.5                        | 88.7                              |
| Van's RV-10            | Lycoming O-540          | 210        | 1225          | 536              | 50                | 169                | 9.68          | 7.44       | 13.7                        | 89.4                              |
| Beathawk               | Lycoming O-540          | 250        | 1225          | 450              | 35                | 135                | 10            | 7.2        | 17                          | 72.1                              |
| Mooney                 | Continental TSIO-550-G  | 280        | 1528          | 454              | 53                | 237                | 11.1          | 8.15       | 16.3                        | 93.7                              |
| <i>Seaplanes</i>       |                         |            |               |                  |                   |                    |               |            |                             |                                   |
| SeaBee                 | Franklin 6A8-215-B8F    | 215        | 1428          | 408              | 52                | 104                | 11.48         | 8.53       | 18.28                       | 78.1                              |
| Nardi FN.333 Riviera*  | Continental IO-470-P    | 250        | 1483          | 440              | 59                | 119                | 10.39         | 7.3        | 15.1                        | 98.2                              |
| Trident TR1- Trigull** | Continental Tiara 6-285 | 285        | 1724          | 590              | 45                | 129                | 12.73         | 8.94       | 21.3                        | 80.9                              |
| Lake Buccaneer         | Lycoming IO 360-A 1B    | 200        | 1220          | 515              | 45                | 126                | 11.6          | 7.6        | 15.79                       | 77.3                              |
| Seawind 300C           | Continental IO-550-N    | 310        | 1542          | 522              | 52                | 165                | 10.67         | 8.28       | 15.14                       | 101.8                             |

Source: company data, \* FN333- Owners Manual, \*\* [http://www.seabee.info/trigull/trigull\\_specs.htm](http://www.seabee.info/trigull/trigull_specs.htm). Trigull can seat six people as well.

loading of  $46 \text{ kg/m}^2$  has a take-off speed of 90 km/hr. The lower wing loading is required to reduce both the distance and speed for take-off. Lower values of wing loading also reduces stall speed. The well-known Fieseler Fi-156 has a wing load of  $48.5 \text{ kg/m}^2$  resulting in its extreme STOL characteristics. This leaves little doubt about the required wing loading. It must be as low as possible given the operating requirements, and ideally less than  $50 \text{ kg/m}^2$  for short and low speed take-off. In fact, measurements from scale drawings show that Flightship-8 has a wing loading of  $55 \text{ kg/m}^2$  even without the large wingtips.

The WIG craft will be propeller driven. At the powers required, piston engines are suitable for the task. Sadraey (2011) discusses how the engine power is determined from considerations of power loading and wing loading. The calculations shows that 160 hp is sufficient for the craft to be airborne even if it is an aircraft. However, the large wing area, and hence the high lift will further reduce this power. The power has to be lower to prevent flight above 150 m for the WIG to be registered as an IMO type BWIG craft as outlined in the introduction. Roskam (1985) discusses how the diameter of propeller can be calculated, once maximum power of the engine and power loading of propeller blades are known. The calculations lead to a propeller of 1.7 m in diameter if two blades, or 1.5 m in diameter if the propeller has three blades. A two-blade propeller is more efficient but a three-blade propeller has the advantage of absorbing more power while having a smaller diameter.

### **Stall speed**

WIG craft require low stall speeds to reduce the impact of the craft on sea and thus structural damage. Strong impacts require strengthening the hull and hence there is a weight penalty. Additionally, Federal Aviation Regulations (FAR) 23 of the USA require that the stall speed be less than 61 knots (113 kmph) for aircraft of MTOW of less than 6000 (2721 kg) pounds. The European Aviation Safety Agency (EASA) requirement of the stall speed of Very Light Aircraft (VLA), i.e., MTOW less than 750 kg, is 45 knots (83 kmph). However, these requirements are easily met because of the large wing area and the WIG effect, not that they have to be as WIG craft are ships and not aircraft according to IMO. Stall speed depends on maximum lift coefficient (wing and airfoil design) as well as the nature of aircushion beneath the wings. For simplicity, high lift devices are not included in the design. The two-seat Airfish 3A has a take-off speed of 40 km/h and a similar value is considered for the stall speed.

### **Wing Airfoil**

The airfoil of a WIG craft has a significant effect on the aerodynamics of the craft. Most of the investigations of airfoils have been on the behaviour of the wing in free air. However, there are a few studies which deal with the behaviour of the airfoil in close proximity to the ground. In this respect, an important family of airfoils is the one called DHMTU airfoils for which data for GE are available. These originate from the Department of Hydrodynamics of the Marine Technology University (DHMTU, Saint Petersburg, Russia). Moore, Wilson, and Peters (2002) conducted a comparative study of one of these airfoils with NACA 0012 and found that DHMTU possesses superior L/D in GE at low angles of attack. Alan (2013) investigated the L/D ratio of NACA 4415 in GE. He found that largest percentage

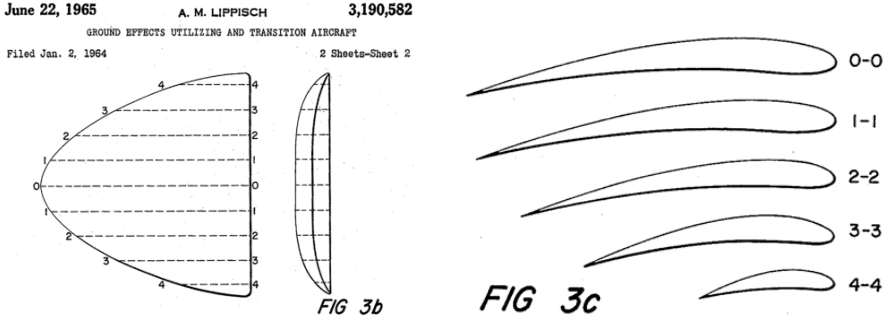

Figure 8. The wing shape is half of an ellipse. The wings are highly under-cambered.

gains in L/D ratios came from the wing at an angle of attack is  $4^\circ$  and the ratio of height above-ground to chord ( $h/c$ ) was below 0.3.

The airfoil used by Lippisch may be gleaned from this patent application. This is shown in Figure 8. The highly under-cambered or decambered airfoil is seen from the patent drawings. The airfoil used in Eska-1 is Clark-Y, perhaps, because of ease of construction as the bottom of the airfoil is flat and Eska-1 was built using pine slats.

The airfoils used in Airfish 3 and Airfish 8 could not be located in the literature. However, it is possible that both have Clark-Y airfoils as an extant photograph taken during the construction of Airfish-8 shows. The photograph is with the author. The

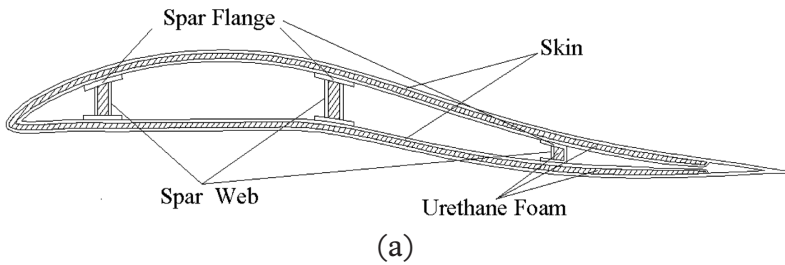

Figure 9. The airfoil (a) of a 20 seat WIG showing sandwich construction (Kong, Park, & Kang (2008)). The image (b) shows the photographically emphasized deep under-cambering of Bavar 2. The airfoil (c) is that of the Chinese craft seen in the Figure 6. It has been enlarged and flipped horizontally so that the orientation of the two images is the same.

bottom of the airfoil is flat in the picture. Rozhdestvensky (2006. p. 244) noted from experimental studies conducted by others that a simple way of enhancing the stability of the Clark-Y airfoil was to use a trailing edge flap turned to an upward position. Experimental and mathematical reasoning confirmed that this was indeed the case. Further, noticeable stability was obtained by de-cambering the bottom of the airfoil. The resulting shape has an S-shaped mean line. Kong, Park, & Kang (2008) studied the airfoil of a WIG craft with a capacity of 20 seats. The study was a preliminary design study focused on structure of the craft. They used a modified NACA 7409 airfoil. Kong et al stated that “the maximum lift coefficient is 0.73 at 4° (in ground effect). Chord lengths at wing root and tip are 7.5 m and 3.0 m, respectively, and halfspan is 9.0 m. The horizontal tail has a chord length of 2.3 m and span of 12.96 m.” (2008, p. 345). Their airfoil is shown in Figure 9 (a). In the same figure the airfoils of the Chinese WIG shown in Figure 9 and Bavar 2 are enlarged and shown.

The above tested and tried airfoils leave no doubt that under-cambering is particularly suitable for WIG craft. There other airfoils which may be considered with de-cambering and the trailing edge turned upwards. They include NACA 23012 used in STOL aircraft Helio 295 Super Courier (U-10), US35b used in Piper Cub and the airfoil of Fieseler Fi 156 Storch—perhaps, the most successful STOL aircraft. In fact, Syamsuar, Djatmiko, Erwandi, Mujahid and Subchan (2016) used NACA 23012 in their investigations of a WIG craft. In order to reduce the take-off power, STOL characteristics in WIG craft are desirable. For the model the author decided to use the Korean one airfoil shown in Figure 9.

## Tail

A feature of all Lippisch WIG craft is the pitch up movement due to high lift. In order to counter the pitch up moment, a large horizontal stabilizer is necessary. This stabilizer is a flying one, in case of Eska, it has the symmetrical NACA 0009 profile with an angle of attack of 5 degrees. Due to the size of the stabilizer, usually two vertical rudders are used to make the structure strong and stable. This is the case for Airfish-3, Airfish-8, Seafalcon and the XTW family of Chinese WIG craft. The approximate wing area and the area of the stabilizer are shown in Table 7 for some Wig craft.

Table 7  
*Lippisch WIG Craft Wing Area and Stabilizer Area*

| WIG craft | Wing area (m <sup>2</sup> ) | Stabilizer area (m <sup>2</sup> ) | Ratio of Stabilizer area to Wing area |
|-----------|-----------------------------|-----------------------------------|---------------------------------------|
| X-114     | 24                          | 5.9                               | 0.25                                  |
| Eska-1    | 13.85                       | 3.7                               | 0.27                                  |
| Airfish 8 | 57.4                        | 13.8                              | 0.24                                  |
| Seafalcon | 32.6                        | 10.17                             | 0.31                                  |

*Source:* estimated planform areas from cited scale drawings and published values

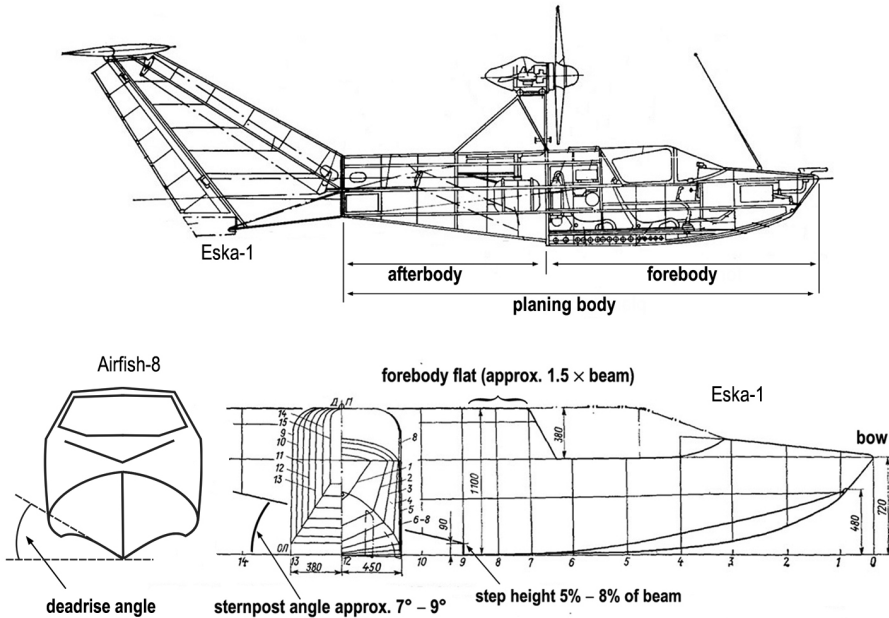

Figure 10. Common terms used in WIG design.

From Table 7, it is seen that the area of the stabilizer is 25% – 31% of the wing area. The value used in the designed WIG was 25%.

### Fuselage or Hull

The fuselage of a WIG as well as a seaplane, is also known as hull. The large number of seaplanes produced for World War II and for the civil market was preceded by much research on the optimum configuration of the hull. The major research outcomes have been summarized by Gudmundsson (2014). A WIG craft hull, just as with all seaplanes have a discontinuity on hull bottom, called a step, to reduce hydrodynamic drag and to allow the WIG to rotate. The step reduces the surface area of water in contact with water and allows the craft to accelerate. At near take-off speed, only the area near the step is in contact with water and thus rotation on this area becomes possible. The length of the hull forward of the step is called the forebody and the length of the hull rear of the step is called afterbody. There are some other terms associated with hulls and norms for some dimensions. Some terms are indicated in Figure 10. A term not mentioned in the figure is the forebody flat which is the flat area just in front of the step. To reduce porpoising, the forebody flat should be 1.5 times beam width (Gudmundsson, 2014). He also notes that the centre of gravity must be in the forebody and within  $10^0$  to  $15^0$  ahead of the step.

A Lippisch WIG hull is necessarily different from that of a seaplane in that some buoyancy is obtained from the sponsons at wing tips. At landing and take-off seaplanes as well as WIG are in ground effect (G.E). Thus the normal rules of seaplane design are used for WIG hulls. The basic design parameters of seaplanes have been experimentally determined by Smith and White (1954, p. 16) and

summarized by Gudmundsson (2014) from a number of studies. The main findings are outlined in Table 8 from these two sources. The norms mention beam load coefficient. This is the ratio of buoyancy force to the product of the cube of beam and density of water. The required formulae and calculations are summarized in Appendix C3 of Gudmundsson (2014).

Table 8  
*Design Norms from Experimental Results*

| Forebody   | Afterbody   | Step   |
|--|---|--|
| <p>(a) Length of the forebody should provide sufficient planning area to keep chines clear at hump. Generally 3 to 3.5 times beam width is sufficient. (As a WIG (or sea plane) accelerates for take-off, water drag becomes the major resisting force. Water drag peaks about a speed of 27 knots just before the hull begins to plane. The speed at which the resistance is greatest is referred to as “hump” because when water drag is plotted against the take-off speed, the resulting curve has a hump at this point. Before and after the hump, water drag is lower).</p> <p>(b) Beam loading should not exceed a coefficient of 1.0 for seaplanes.</p> <p>(c) Dead-rise should be small at the step (order of 20 deg), and increased forward at about 5 deg per beam length.</p> <p>(d) Flare is advantageous at large load coefficients.</p> | <p>(a) Length should be as short as possible, 2 to 2.5 beam with transverse rear step, 2.5 to 3.0 beam with pointed rear step.</p> <p>(b) The afterbody keel should rise at not less than 7 deg from the forebody keel at the step. If ventilation is poor or loading coefficient is high, increase up to 10 deg is advisable.</p> <p>(c) Dead-rise angle should be 20 to 25 degrees near the step for good hump stability. Warping of the afterbody is advisable for good ventilation and landing stability.</p> <p>(d) There should be no flare.</p> <p>(e) A pointed rear step in planform helps ventilation (landing stability) but requires a longer afterbody for hump stability.</p> | <p>(a) Step depth for conventional designs should be at least 8 per cent beam for load coefficients of 0.8, after keel angle 8 degrees, afterbody length 2.5 to 3.0 beam, pointed rear step. This is increased to 10 per cent for 3 to 3.5 beam afterbody length, reduced by 1 or 2 per cent for full forebody and afterbody warping, reduced 1 to 3 per cent with artificial ventilation at the step.</p> <p>(b) Step fairings of 6 times the step depth defined above is permissible. With ventilation an 8 to 1 and possibly 10 to 1 fairing would be feasible.</p> <p>(c) A pointed form of any plan shape will help landing stability but tends to raise the lower limit.</p> <p>(d) Roughness on the bottom can lower both limits the order of 4 degrees; behind the step it has no effect until it is large enough to be equivalent to a fairing—then it has no effect as long as the change of angle at the step is sharp and not less than about 20 degrees, and there is adequate ventilation.</p> |

A very useful analysis of dimensions of seaplane hulls is given by Hugli and Axt (1951). They scaled principal hull dimensions of 13 small flying seaplanes to a gross weight of 3000 pounds (1361 kilograms) and calculated design norms. They noted that the hull design issues of large seaplanes are different from those of small ones. The larger hulls are less sensitive to the hydrodynamic resistance characteristics than smaller ones because large hulls have lower power loadings and lower take-off speed coefficients. Additionally, refinements such as chine flare and deadrise warping are not usually feasible in smaller hulls because of the smaller size. A summary of their findings is shown in Table 9.

Table 9  
*Mean Principal Hull Dimensions of Seaplanes (of scaled gross weight 1361 kg)*

|         | <i>Forebody length</i> | <i>Afterbody length</i> | <i>Beam at step</i> | <i>Step height</i> | <i>Step deadrise angle</i> | <i>Sternpost angle</i> |
|---------|------------------------|-------------------------|---------------------|--------------------|----------------------------|------------------------|
| Average | 3574                   | 2840                    | 1199                | 81                 | 20                         | 9                      |
| Maximum | 4724                   | 4056                    | 1412                | 104                | 25                         | 13                     |
| Minimum | 2863                   | 2134                    | 1054                | 56                 | 7                          | 8                      |
| A       | 3822                   | 3969                    | 1169                | 98                 | 20                         | 8                      |
| B       | 3813                   | 2773                    | 1200                | 120                | —                          | 8                      |

*Note:* Dimensions are in mm and degrees. The values shown in A are for the hull Hugli and Axt (1951) designed. The average, maximum and minimum are values of the 13 seaplanes in the reference cited. B values are shown for Eska-1 scaled so that the beam width at step is 1200. The deadrise angle is not clearly visible in any available drawings of Eska-1.

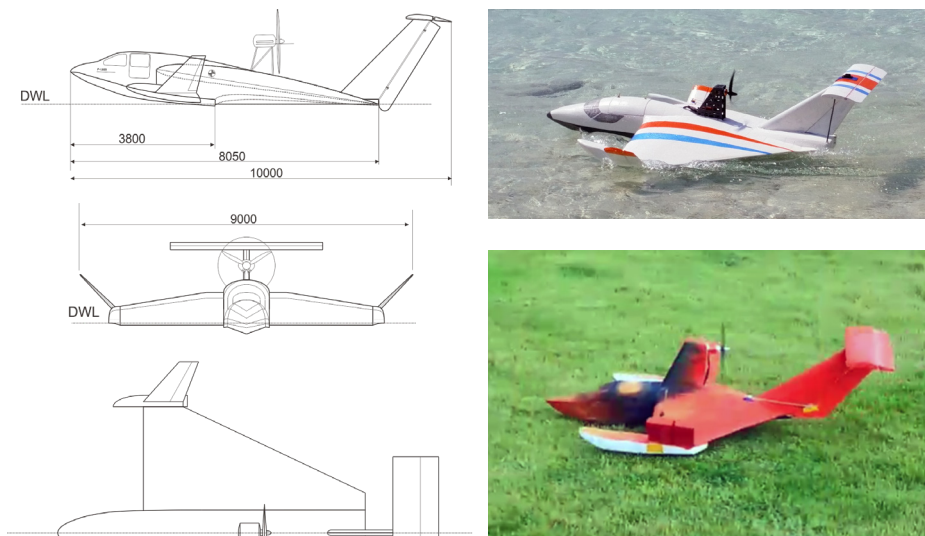

Figure 11. Dimensions of the full-scale WIG craft. The one-sixth scale model is shown on the right above. Below that is a one-seventh scale model with Clark-Y airfoil used in an earlier investigation.

The scholars then continued with the design of a 3000-pound hull of their own. The various decisions they made regarding dimensions of different sections are outlined in their report. In Table 9, the dimensions of the hull are also shown. From the study of the foregoing, the dimensions of the hull design finally decided upon are shown in Table 10.

### **Fabrication of the Experimental Craft**

After suitable calculations and decisions on the final the dimensions of the design, of the WIG craft, a full-scale craft was drawn using Autocad. The craft is shown in Figure 11 with the model. The fabrication of the craft at 1/6th size of full-scale was then contracted out to a group of model aircraft builders. The contractors used laser-cut bulkheads for accuracy. It was built using blue foam, sandpapered and painted. The thrust obtained was 1.0 kg force (9.8 N) using an electric outrunner motor and two-blade propeller. The total weight of the model was 2.5 kg, giving a thrust to weight ratio of 0.4. Scaling aircraft is not straightforward as weight is scaled down by a factor of power 3 and the lift is scaled down faster at power of 4. This phenomenon involves increasing the relative power level or wing area of the aircraft. The issues in scaling are discussed by Weaks (2012).

Table 10  
*Dimensions of the 4-seat WIG craft*

| Dimension                                | Value |
|--|-------|
| Gross weight (kg)                        | 1200  |
| Length of forebody (mm)                  | 3800  |
| Length of afterbody (mm)                 | 4250  |
| Beam (maximum) (mm)                      | 1200  |
| Beam (at step) (mm)                      | 1200  |
| Deadrise at step (degrees)               | 20    |
| Step height (mm)                         | 100   |
| CG location before step (mm)             | 55    |
| CG location above forebody keel (mm)     | 795   |
| Wing span (mm)                           | 9000  |
| Wing area (m <sup>2</sup> )              | 22.6  |
| Stabilizer area (m <sup>2</sup> )        | 4.8   |
| Wing incidence angle with keel (degrees) | 4.5   |

### **Results and Conclusions**

Testing was carried out in the lagoon on the Eastern side of Vilin’gili—an island close to Male’, the capital island. Tests were also carried out in the inner harbour of Male’ which is sheltered from larger waves by a breakwater. In some instances, a GoPro camera was mounted on the tail to observe flying characteristics.

This project has two main purposes. One was to gather the significant engineering information on Lippisch-type WIG craft through an extensive literature review. The second purpose was to design and test a one-sixth size model of a four-seat WIG craft using the principles that had been used in the design of previous WIG craft.

The purpose of building and testing a model is to locate as many issues as possible before building a full-scale model. It is difficult to optimize the parameters for the model because so many variables are interdependent. Thus, the emphasis was on designing the WIG craft which shows good stability. Two models were built and flown. It was found that the WIG craft with Clark-Y airfoil flew better than the one with airfoil suggested by Kong et al (2008). With both models, it was found that the take-off run was excessive, in part, due to higher wing loading. Certain parameters were found to be necessary for WIGs to be flyable. They are that the wing loading must be less than 70 kg per square metre and that the stabilator area must be about 25% of the wing area. Without these parameters, the control of the craft is problematic; greater power loading is required and the WIG tends to stall.

The hull design principles were validated by the testing. However, in future testing the thrust line of the craft and the wing's angle of attack may be made easily variable so that the optimum angle can be found. Different methods may be tested to reduce take-off run such as the use of air bubbles to decrease hydrodynamic drag and boundary layer control methods. If the WIG is to be commercially successful, a shorter take-off run is essential.

## References

- Alan, K. F. F. H. (2013). *Ground effect on a lift generating body*. Unpublished Masters thesis, National University of Singapore. Downloaded from <http://www.scholarbank.nus.edu.sg/bitstream/handle/10635/47351/KOHFH%202013.pdf?sequence=1>
- Chris B. (July 5, 2015). Iran's Building a New Flying Boat. Downloaded from <http://www.offiziere.ch/?p=21490>
- Cole, T. (1989). License to fly. *Popular Mechanics*, July 1989, p. 57.
- Gudmundsson, S (2014): *General aviation aircraft design: Applied methods and procedures*. Oxford: Elsevier. The relevant appendix may be downloaded from [http://booksite.elsevier.com/9780123973085/content/APP-C3-DESIGN\\_OF\\_SEAPLANES.pdf](http://booksite.elsevier.com/9780123973085/content/APP-C3-DESIGN_OF_SEAPLANES.pdf)
- Halloran, M., & Sean O'Meara, S. (1999). *Wing in ground effect craft review*. Defence Science and Technology Organization, Melbourne.
- Hameed, H. (2016). Ekranoplans: An introduction. Downloaded from [http://www.hassanhameed.com/?page\\_id=3714](http://www.hassanhameed.com/?page_id=3714)
- Hillabone, A. (2012) *The hovercraft: A history*. Gloucestershire, UK: The History Press.
- Hugli, W. C. & Axt, W.C. (1951). Hydrodynamic Investigation of a series of Hull models suitable for small flying boats and amphibians (*NACA Technical Note-2503*). Washington: NACA.

- IMO. (2002). *Interim guidelines for Wing-in-Ground (WIG) craft*. MSC/Circ.1054. 16 December 2002/ London: IMO
- Kong, C., Park, H., & Kang, K. (2008). A study on conceptual structural design of wing for a small scale WIG craft using carbon/epoxy and foam sandwich composite structure. *Advanced Composite Materials*, 17, 353–358.
- Moore, N., Wilson, P.A., & Peters, A.J. (2002). An investigation into wing in ground effect aerofoil geometry. In, RTO-MP-095. *RTO SCI Symposium on Challenges in Dynamics, System Identification, Control and Handling Qualities for Land, Air, Sea and Space Vehicles* Paris, France, NATO RTO, 11-[20pp].
- National Bureau of Statistics. (2016). *Maldives Key Indicators, 2003*. Downloaded from <http://statisticsmaldives.gov.mv/nbs/wp-content/uploads/2015/09/keyindicators-2003.pdf>
- Roskam, J. (1985). *Airplane design, Part I: Preliminary sizing of airplanes*. Lawrence, KS, USA: Roskam Aviation and Engineering Corporation.
- Rozhdestvensky, K.V. (2000). *Aerodynamics of a lifting system in extreme ground effect*. Berlin:Springer-Verlag
- Rozhdestvensky, K.V. (2006). Wing-in-ground effect vehicles. *Progress in Aerospace Sciences*, 42 (3), 183–211. <http://dx.doi.org/10.1016/j.paerosci.2006.10.001>
- Russian Lifeboats can fly. *New Scientist*. 689–690, March 14, 1974
- Sadraey, M.H. (2012). *Aircraft design: A systems engineering approach*. West Sussex: Wiley
- Sammyanddaiana. (November 10, 2012). Iran launches new combat flying boat [Videofile]. Retrieved from <https://www.youtube.com/watch?v=QjgvY4SnHKM>
- Smith, A.G., White, H.G. (1954). *A review of porpoising instability of seaplanes*. Aeronautical Research Council. London: Her Majesty's Stationery Office
- Stealth flying boats join IRGC fleet. (2010). Dated Tue Sep 28, 2010 4:59PM. Downloaded from <http://www.presstv.ir/detail/144395.html>
- Syamsuar, S, Djatmiko, E.B., Erwandib, Mujahid. A.S., & Subchan. (2016). The hydroplaning simulation of flying boat remote control model. *Jurnal Teknologi (Sciences & Engineering)* 78 (6), 191–197.
- Weeks, G. (2012). Scale Weight effect on Flight Performance. Downloaded from [http://geodza.com/PMAC\\_Web\\_2012\\_live/In\\_The\\_Shop\\_files/Weight%20and%20flight%20performance%20of%20scale%20models%20by%20Gary%20Weeks.pdf](http://geodza.com/PMAC_Web_2012_live/In_The_Shop_files/Weight%20and%20flight%20performance%20of%20scale%20models%20by%20Gary%20Weeks.pdf)
- WIG aircraft. (2013). WIG aircraft – a new joint project between Russia and China. Downloaded from [http://voiceofrussia.com/2013\\_04\\_26/Wig-aircraft-a-new-joint-project-between-Russia-and-China/](http://voiceofrussia.com/2013_04_26/Wig-aircraft-a-new-joint-project-between-Russia-and-China/)
- Yun, L., Bliault, A, & Doo, J. (2010). *WIG craft and Ekranoplan: Ground Effect Craft Technology*. New York: Springer.
- Грунин ЭСКА-1 (n.d.) Retrieved from <http://airspot.ru/catalogue/item/grunin-eska-1> on November 6, 2014.